

41 Bandă de alergare

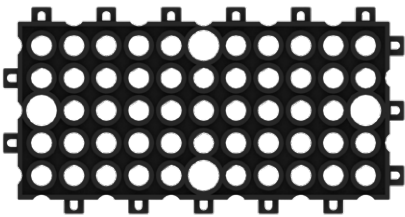

Piese



Bloc 5x11 (4)

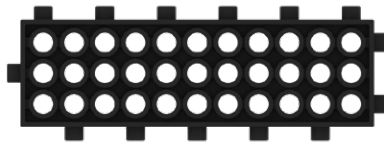

Bloc 3x11 (1)



Angrenaj S (2)

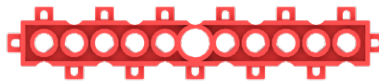

Bloc 1x11 (4)



Bloc oval (2)

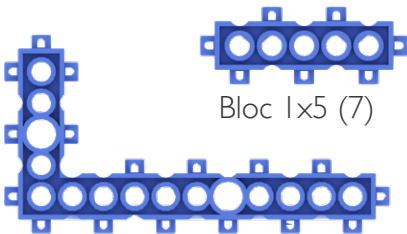

Bloc de 90° (3)

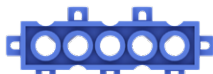

Bloc 1x5 (7)

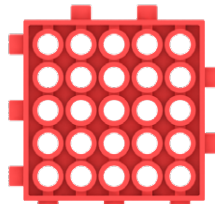

Bloc 5x5 (1)

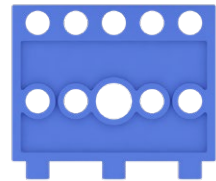

Suport de motor (1)

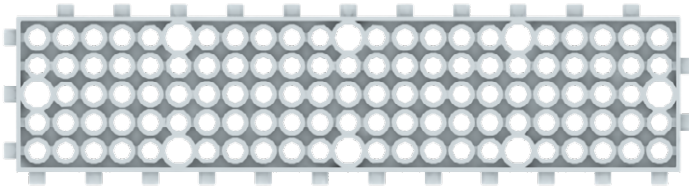

Bloc 5x23 (1)

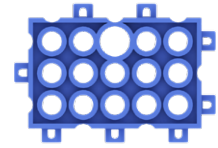

Bloc 3x5 (1)



Bloc N 1x5 (1)



Bloc N 1x7 (2)



Bloc N 1x11 (2)



Conector
de ax (4)



Bloc N 2x9 (2)



Bloc N 2x11 (2)



S-shaft

Ax S (2)



L-shaft

Ax L (1)



Piuliță (4)



Bloc de îmbinare 2 (1)



Bloc curbat (2)



Cauciuc roșu
de ax (8)



Bloc cu ax (2)



Angrenaj L (2)



Potențiomtru (1)



Acumulator 1 (1)

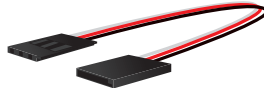

Prelungitor (1)

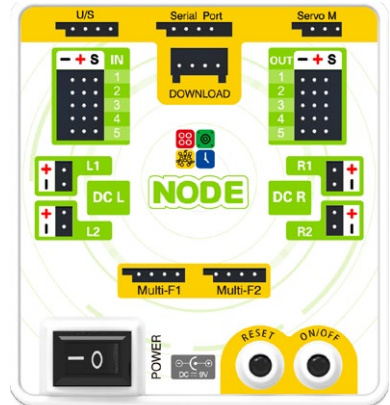

Placă de bază NODE (1)



Cablu de conectare (3)



Acumulator 2 (2)



Motor 2 (1)

01

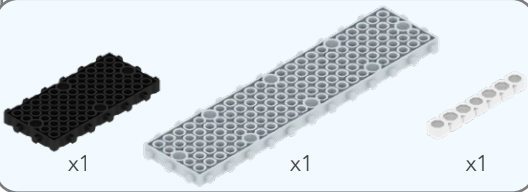
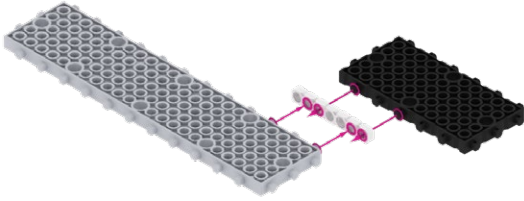

02

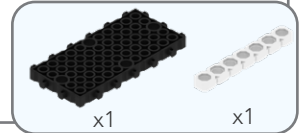
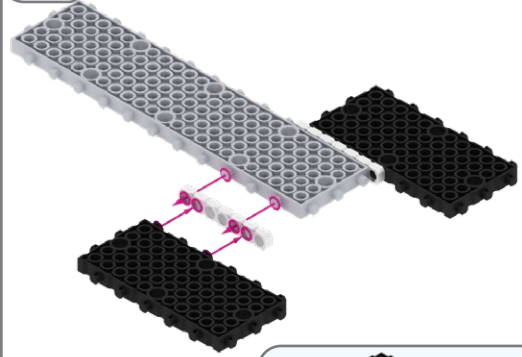

03

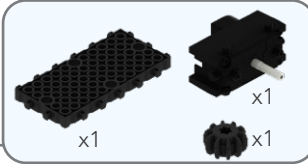
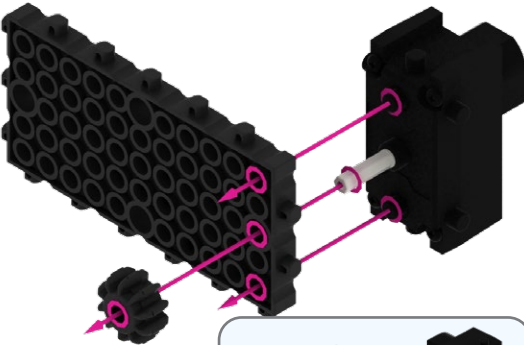

04

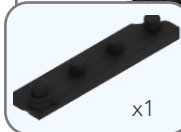
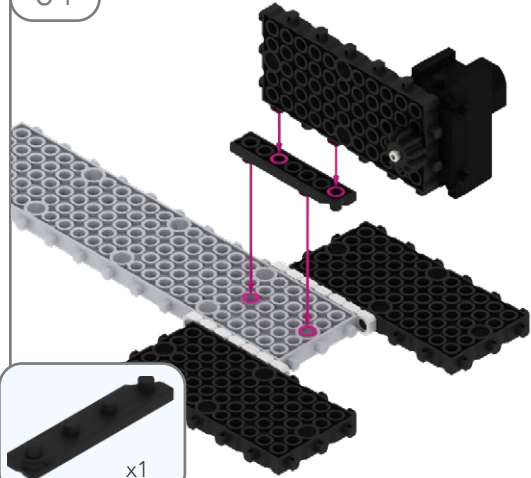

05

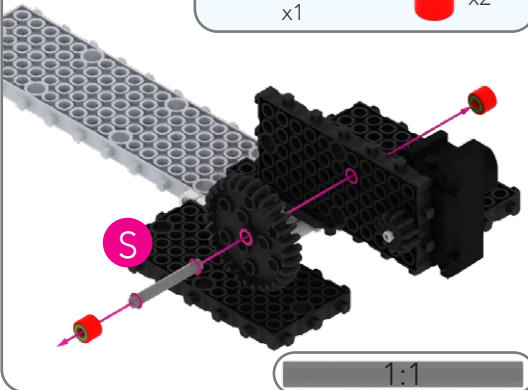
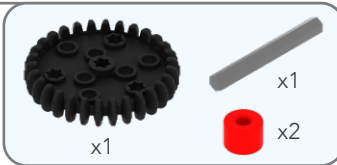

06

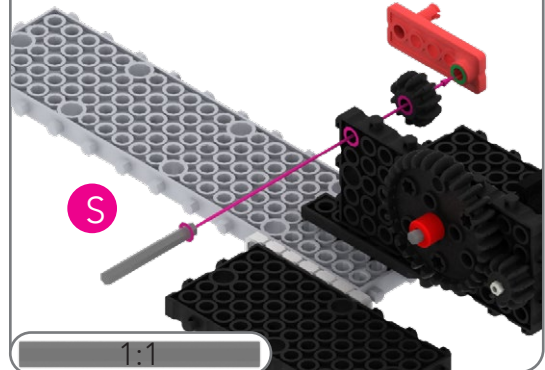
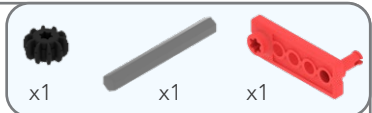

07

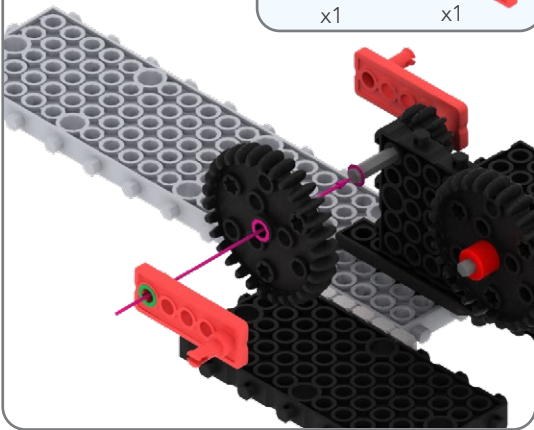
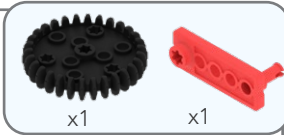

08

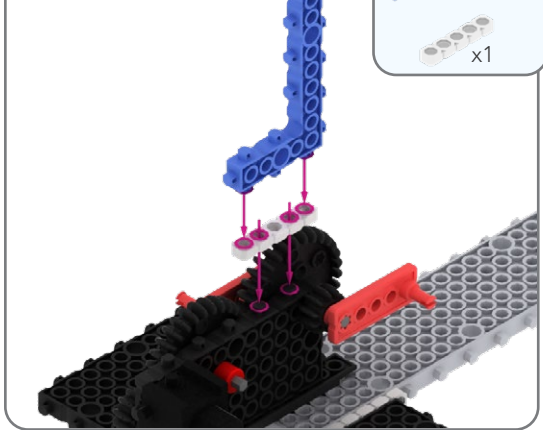
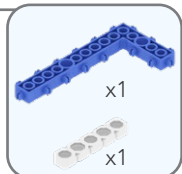

09

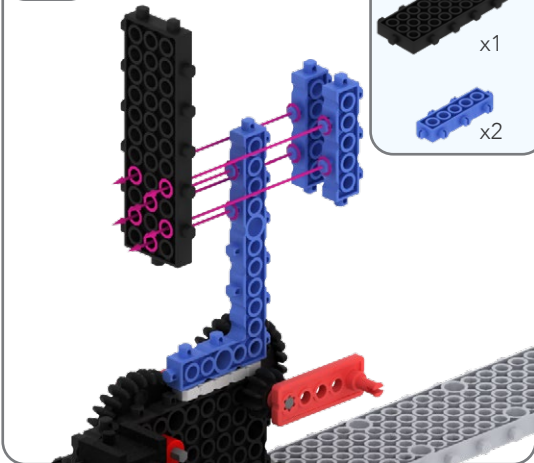
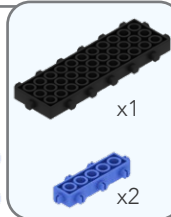

10

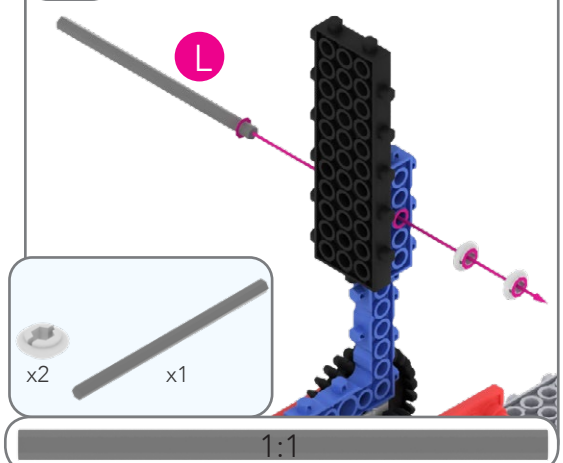
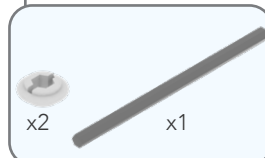

11

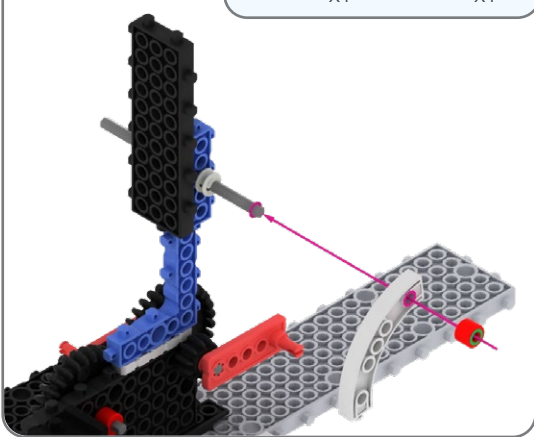

12

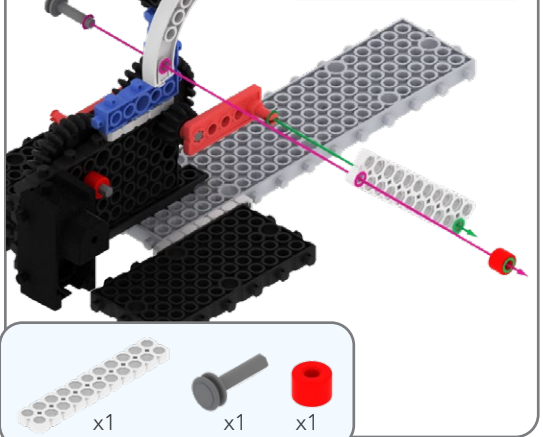
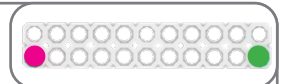

13

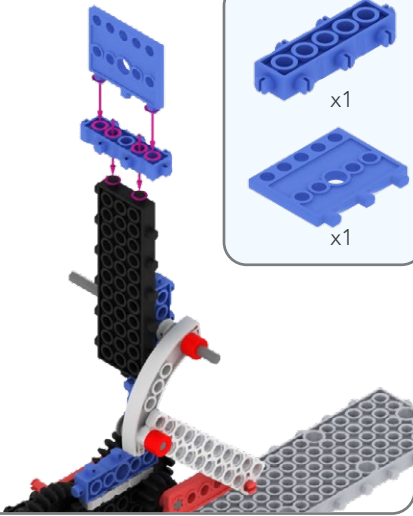

14

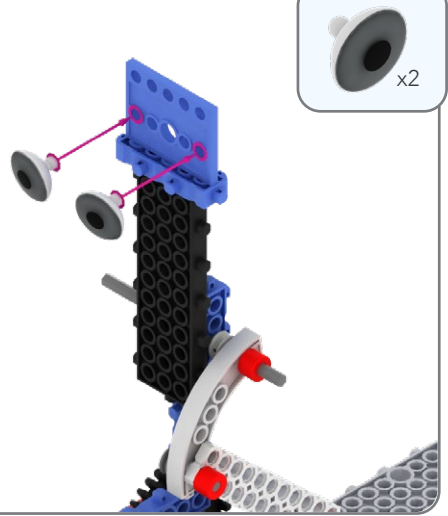

15

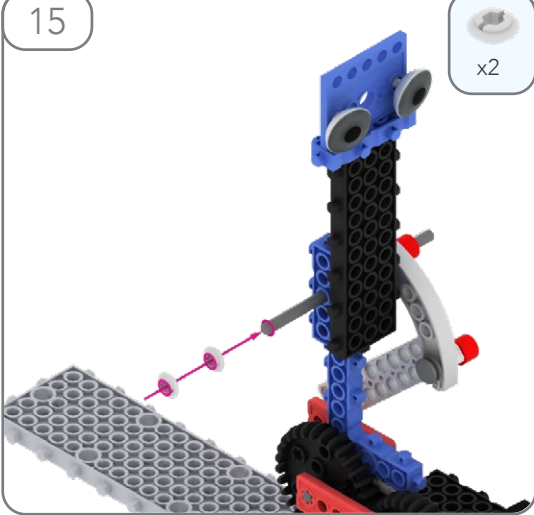

16



17

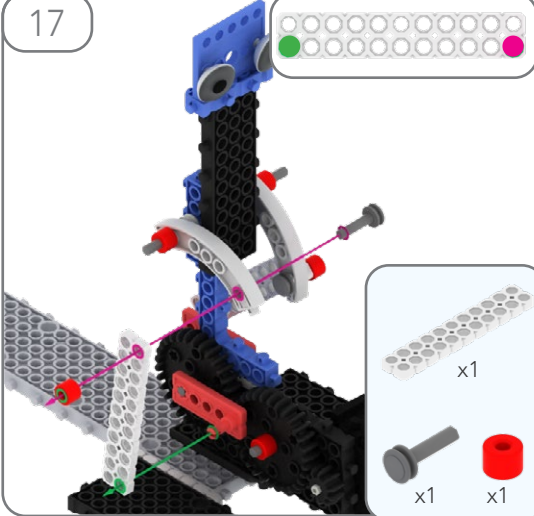

18

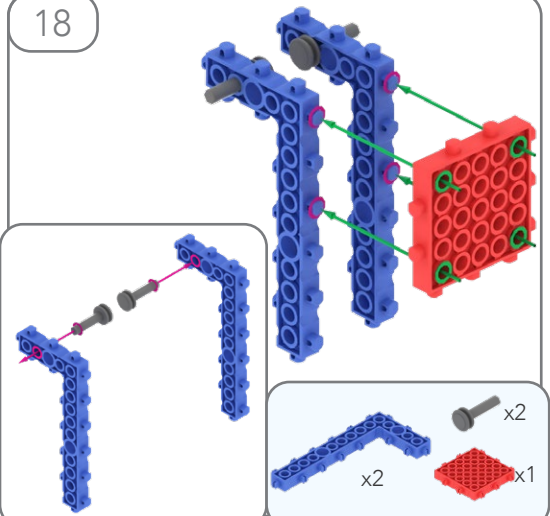

19

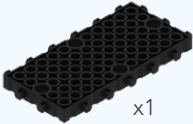
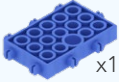
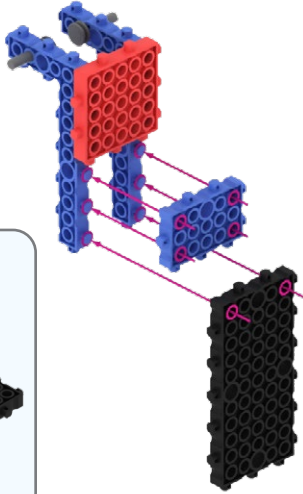

20

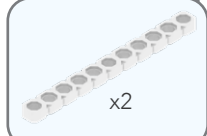
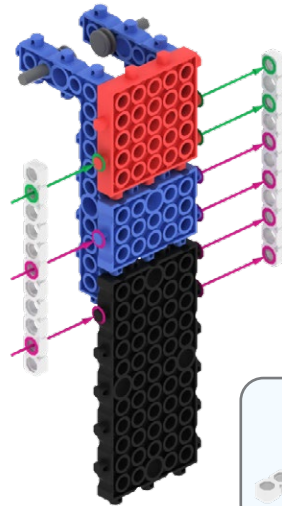

21

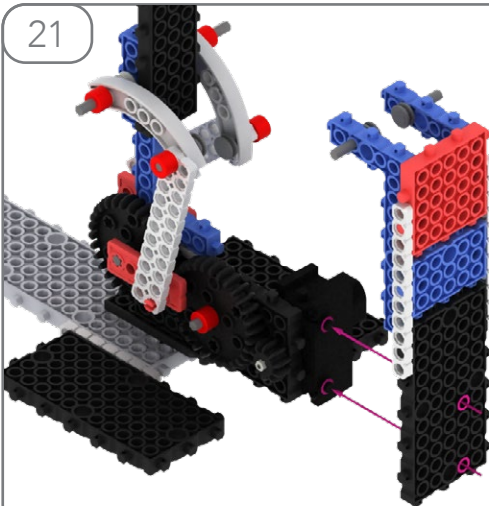

22

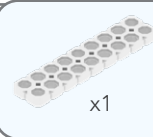
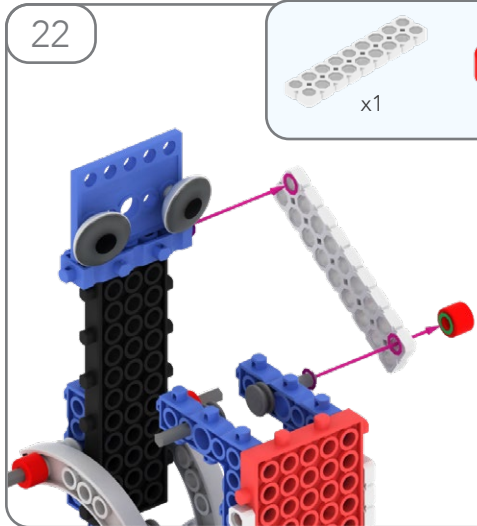

23

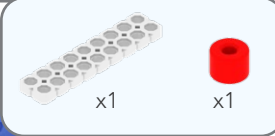
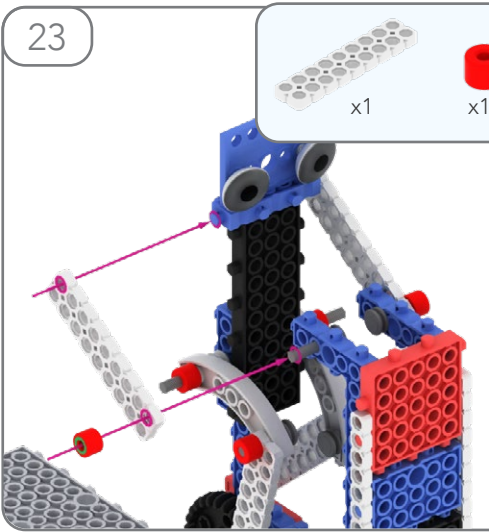

24

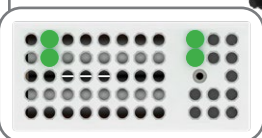
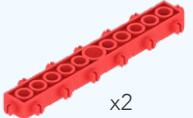
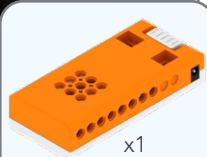
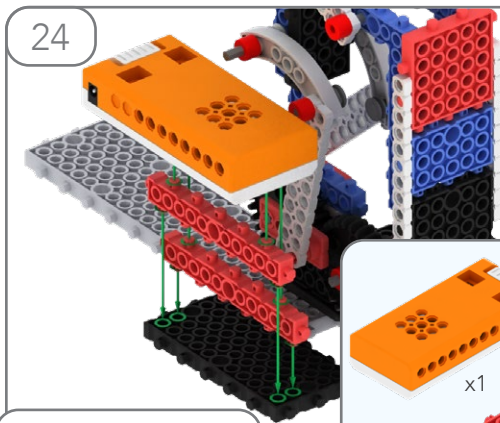

25

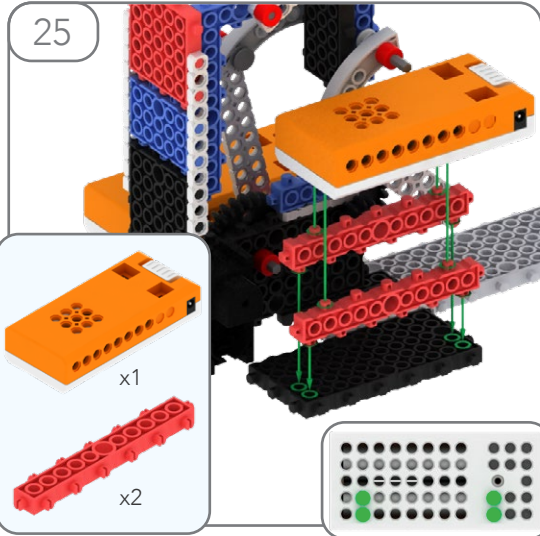

26

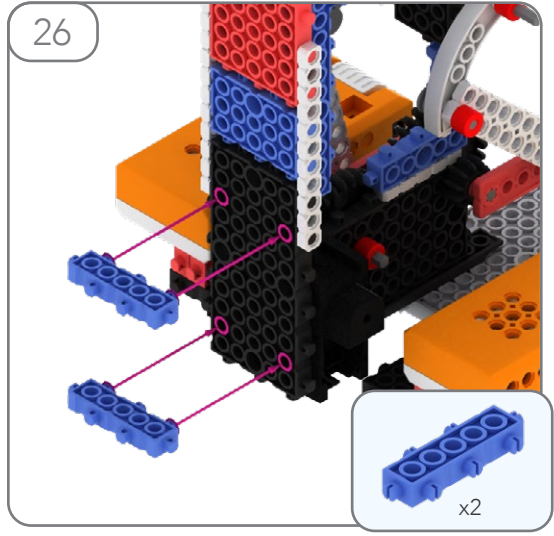

27

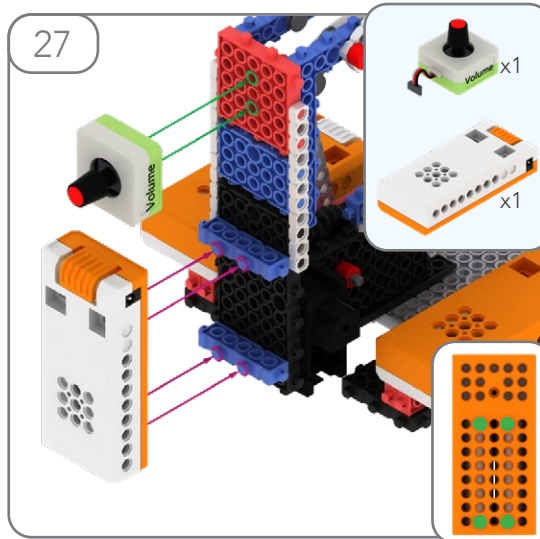

28

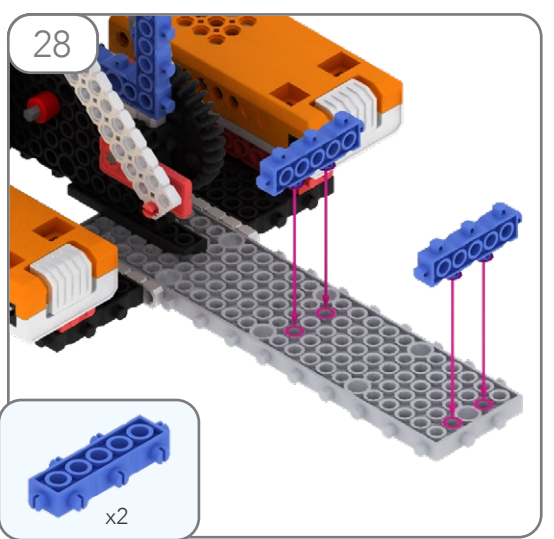

29

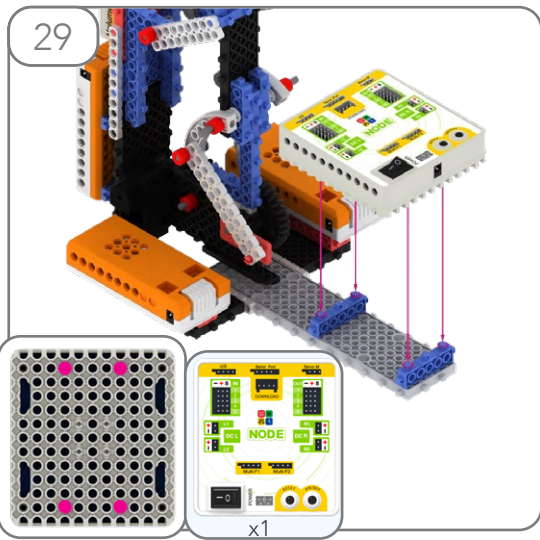

OK



Cum se conectează?

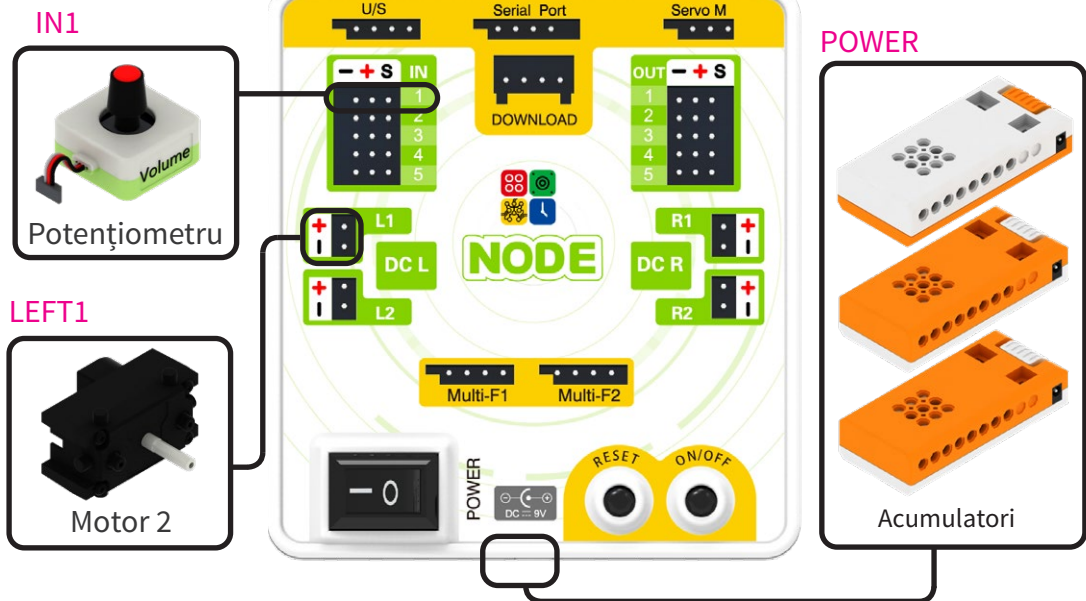

Cum se conectează acumulatorii

Se conectează la placa de bază

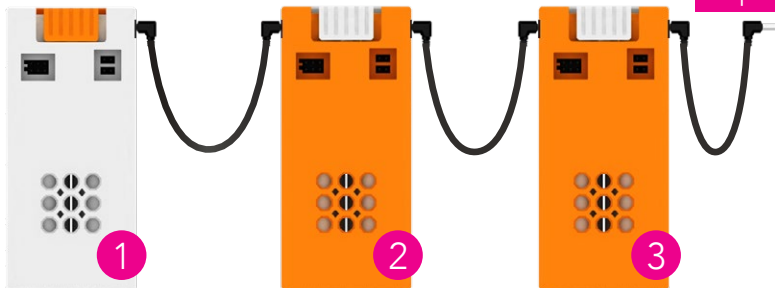

1. Fă clic pe butonul „Coding”, aflat în stânga, pentru a ajunge în interfața de programare.



2. Fă clic pe „Samples” pentru a vedea câteva configurații cu titlu de exemplu.



3. Fă clic pe „Treadmill”.

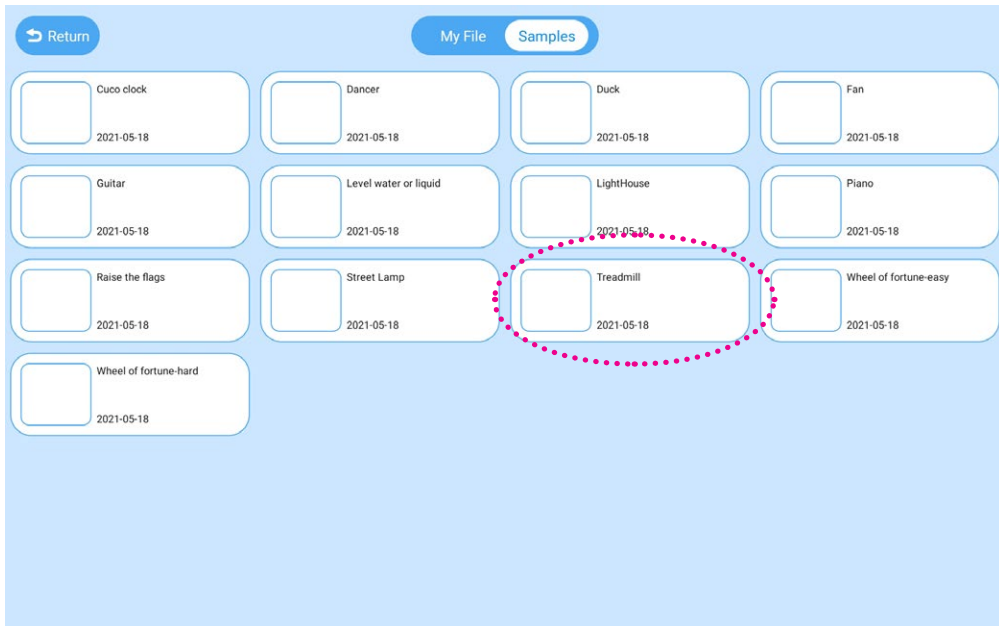

(0-100)

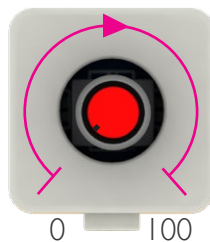

Potențiometrul are valori de la 0 la 100.