

47 Pian

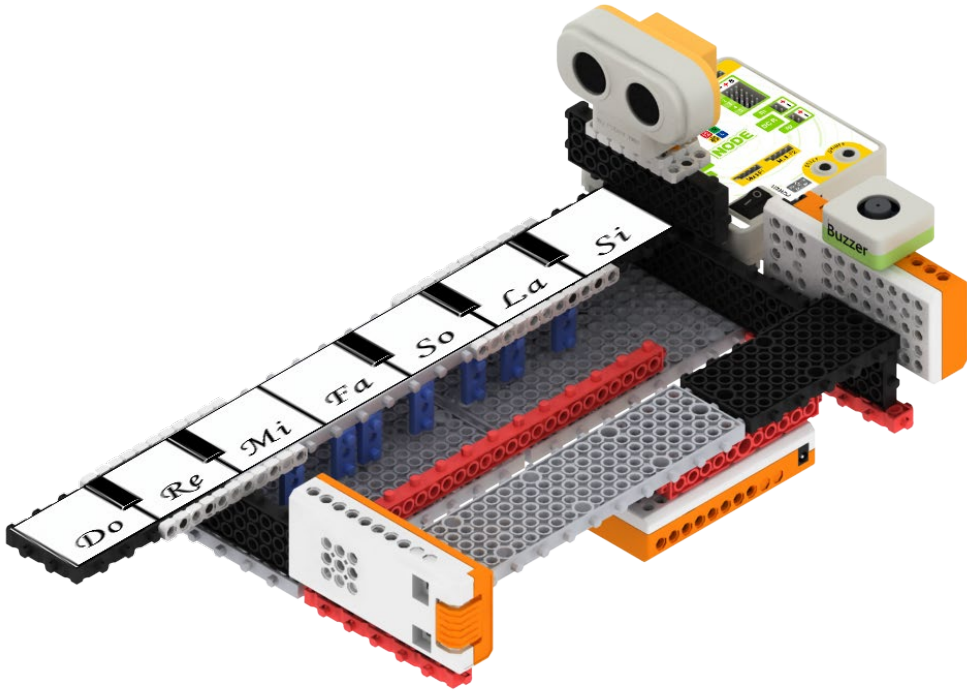

Piese

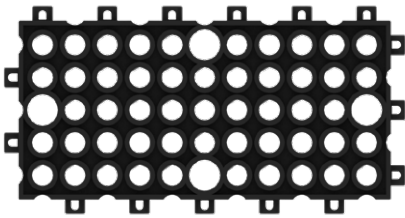

Bloc 5x11 (3)

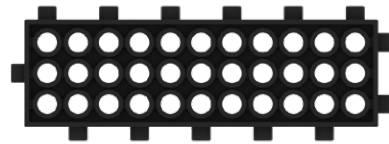

Bloc 3x11 (1)



Adaptor L (7)

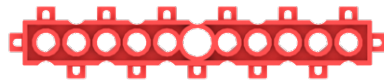

Bloc 1x11 (4)

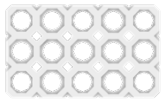

Bloc 3x5 N (1)

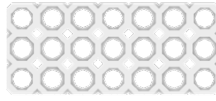

Bloc 3x7 N (1)



Bloc 1x11 N (4)

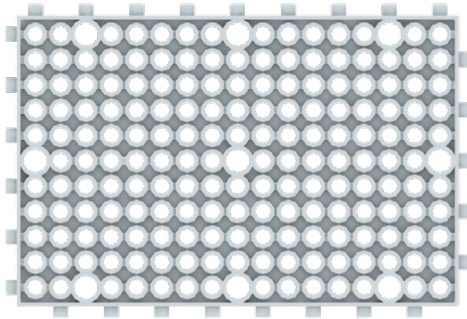

Bloc 1x17 (2)

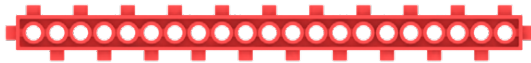

Bloc 1x21 (2)

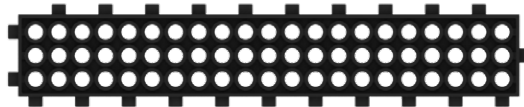

Bloc 3x21 (2)

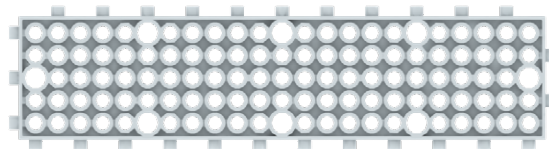

Bloc 5x23 (2)



Nit 5 (2)



Buzzer (1)

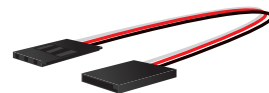

Prelungitor (1)



Senzor cu ultrasunete (1)

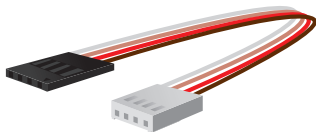

Cablu pentru ultrasunete (1)



Cablu de conectare (3)



Acumulator 1 (1)



Acumulator 2 (2)

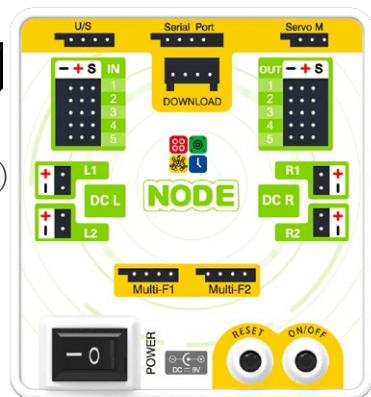

Placă de bază NODE (1)

01

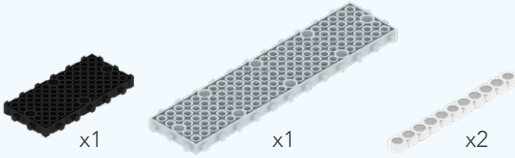
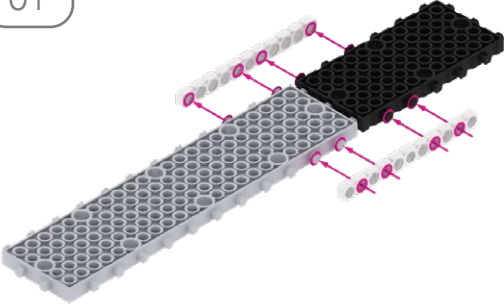

02

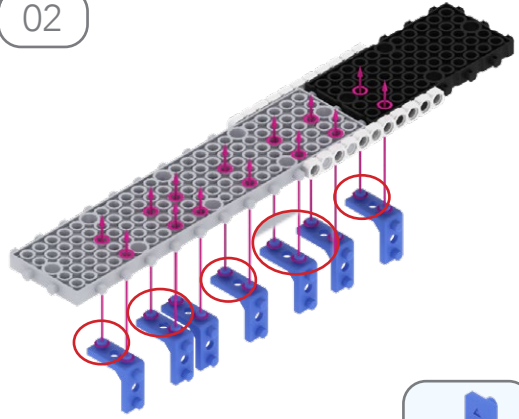

Triunghiul roșu „▲” indică poziția.



03

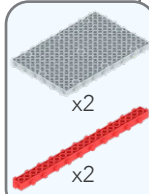
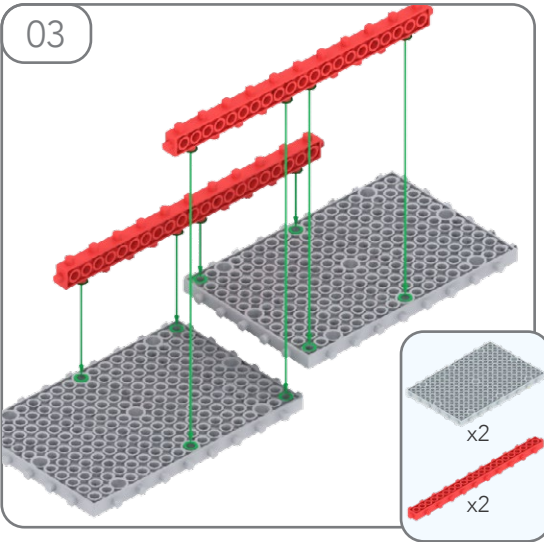

04

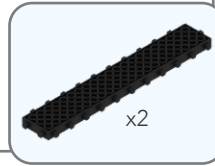
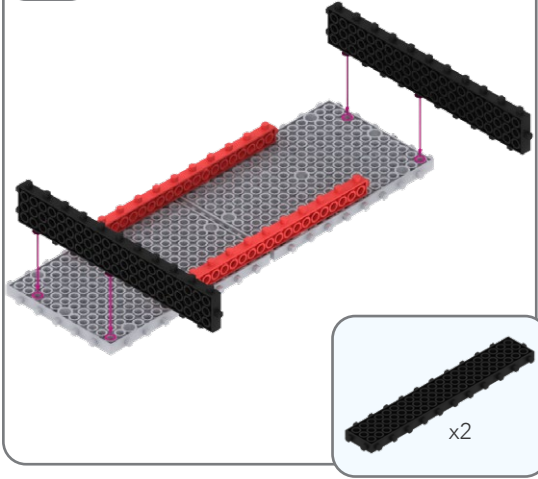

05

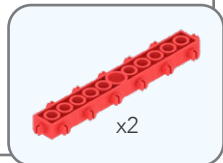
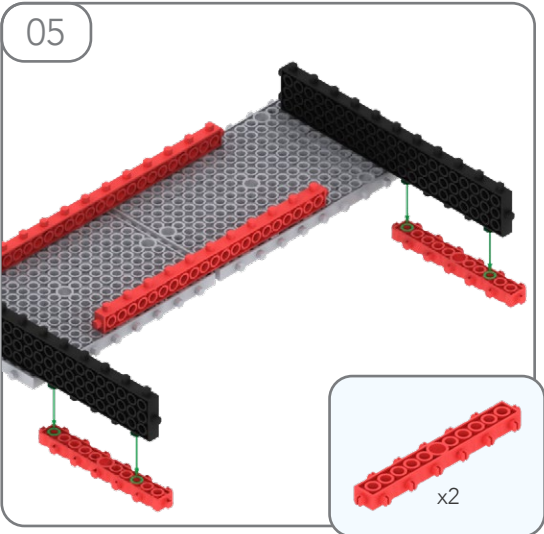

06

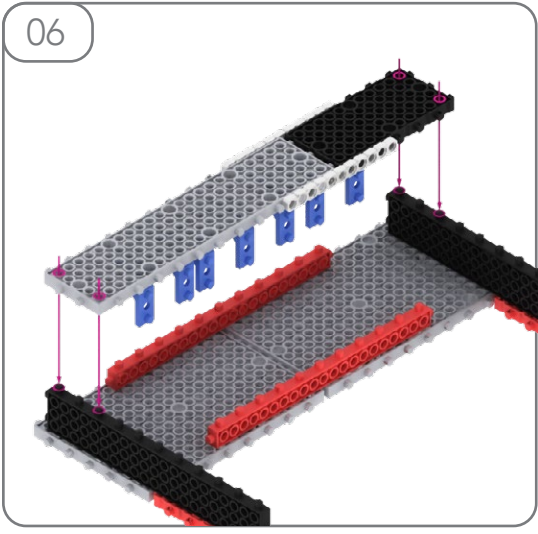

07

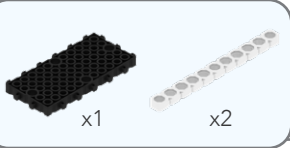
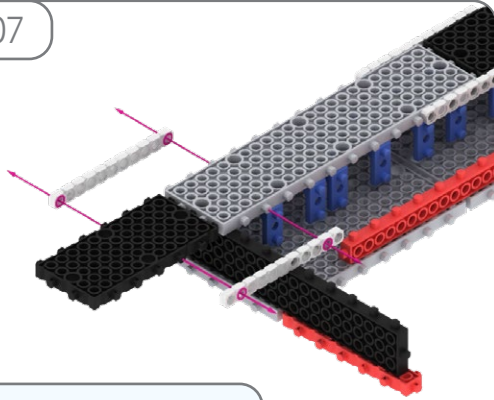

08

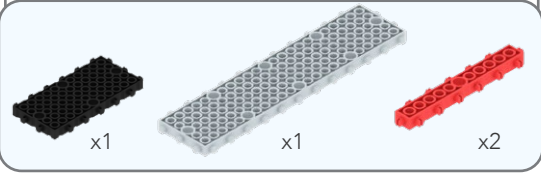
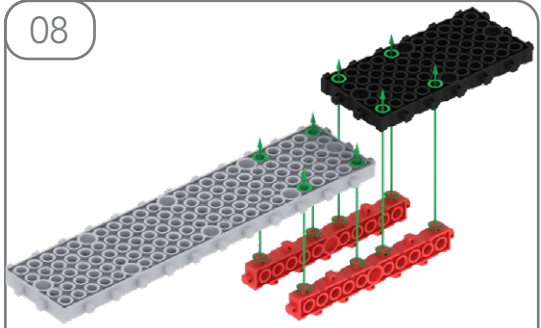

09

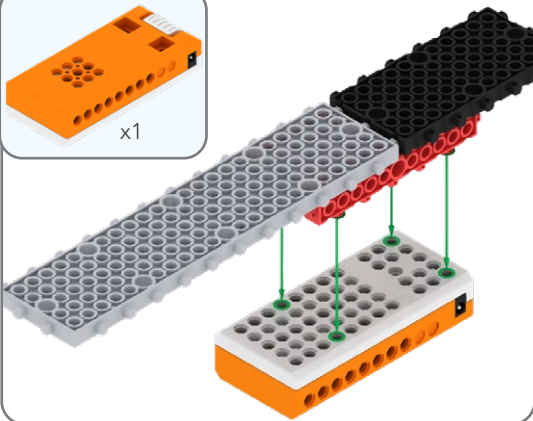
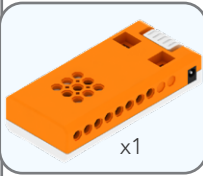

10

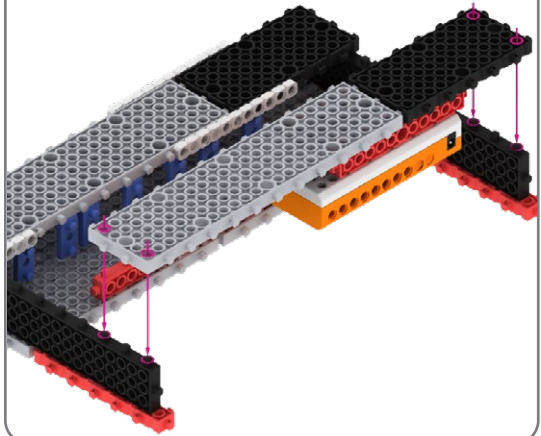

11

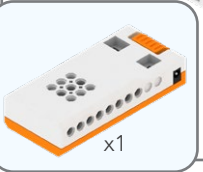
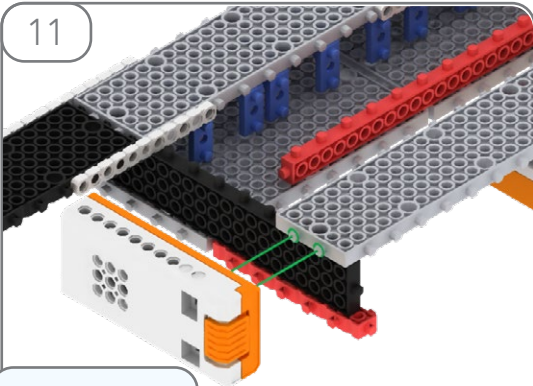

12

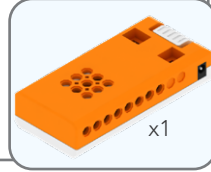
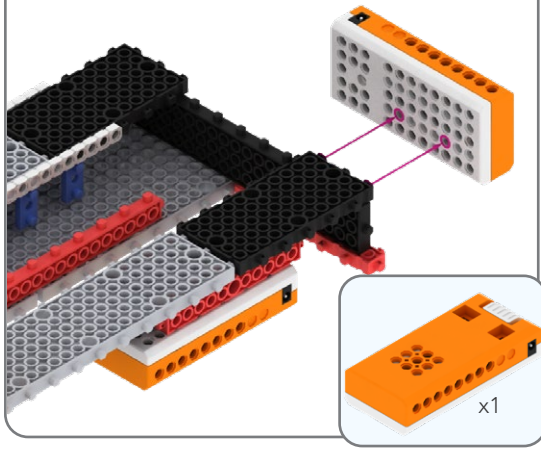

13

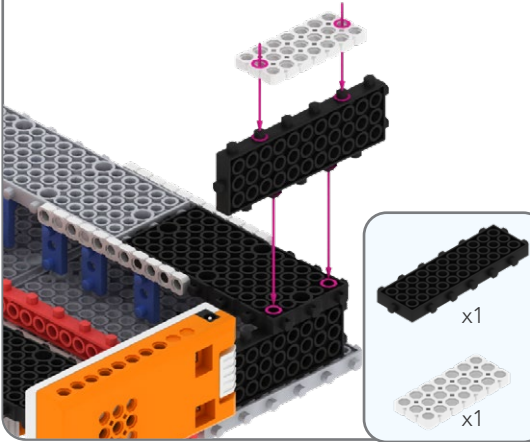

14

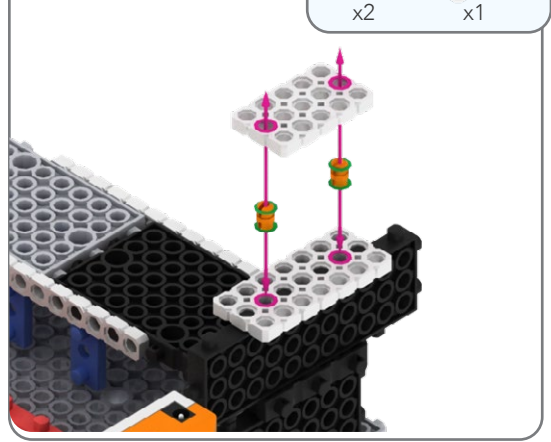

15

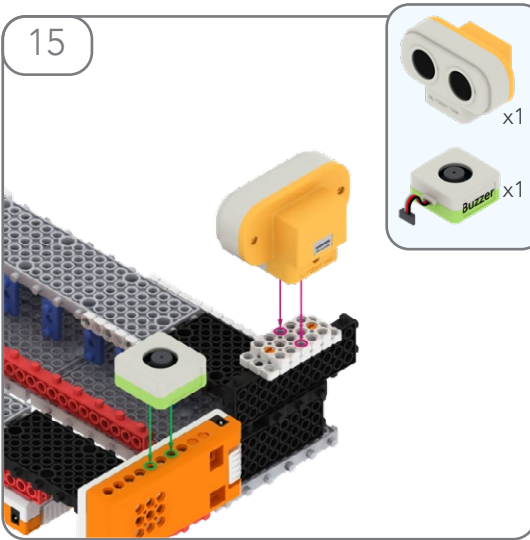

16

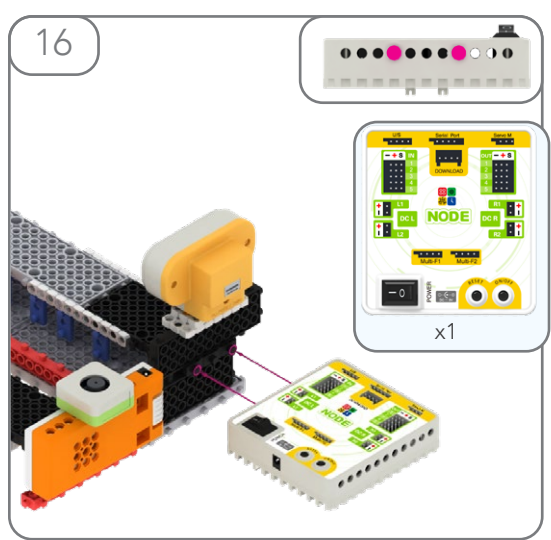

OK

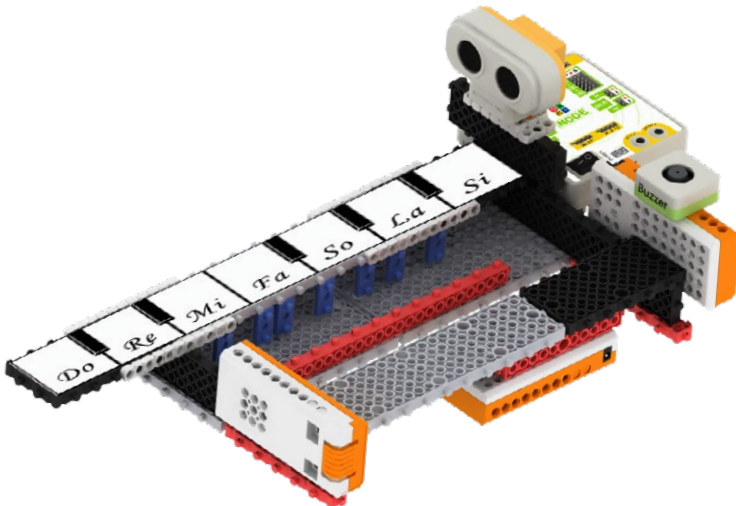

Cum se
conectează?

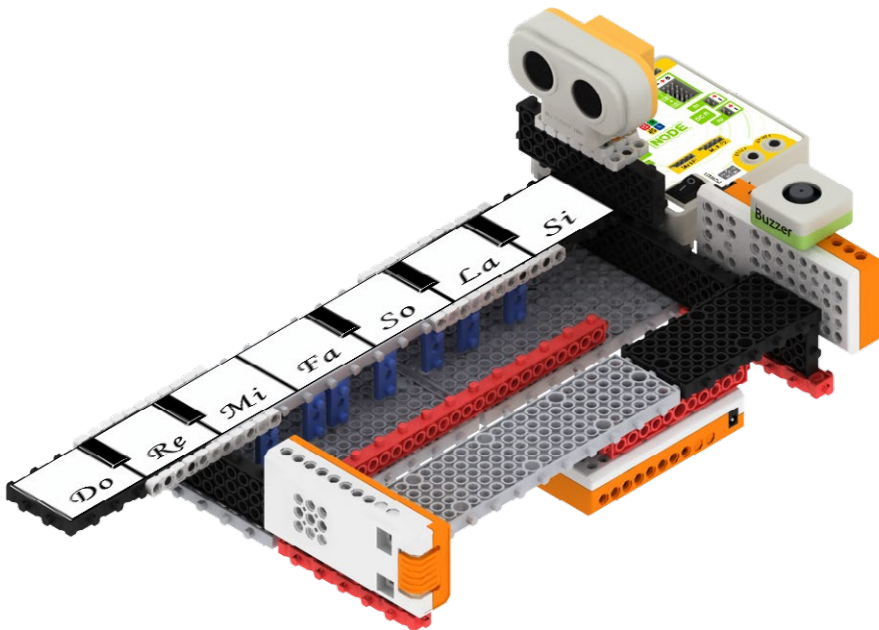
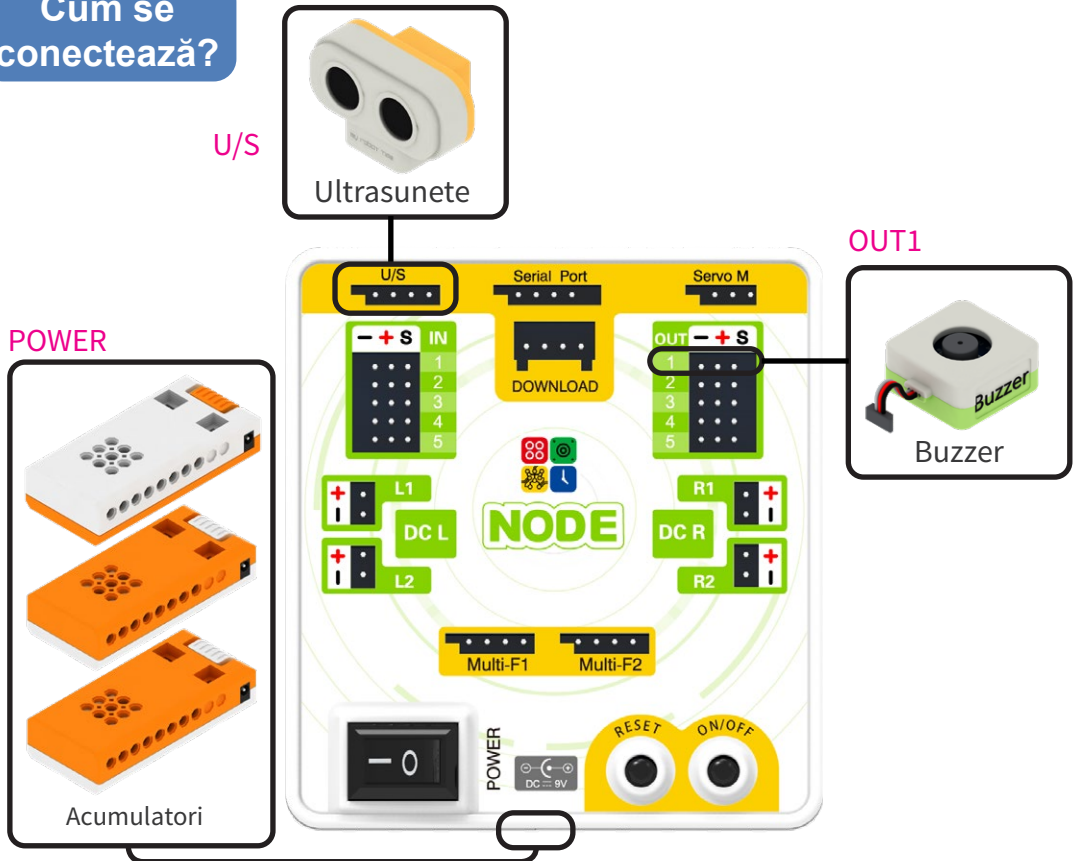

În practică

1. Fă clic pe butonul „Coding”, aflat în stânga, pentru a ajunge în interfața de programare.



2. Fă clic pe „Samples” pentru a vedea câteva configurări cu titlu de exemplu.



3. Fă clic pe „Piano”.

